



**NOGAMT**

**ULTIMATE SERIES**  
MACHINE TOOLS



## ULTIMATE SERIES

### Machine Industry & Global Partners

For more than 40 years NOGA has been recognized worldwide for its state-of-the-art Hand Deburring Tools, designed to be used extensively in industrial applications.

In recent years there has been a demand for dedicated machine deburring tools external and internal back holes for the metalworking and machining industry.

Today we are proud to introduce our new line of NOGA MT – Machine Tools.

**NOGA MT Ultimate** series products line designed for front and back Deburring, back Spotfacing and back Chamfering in a single pass through a hole.



## ULTIMATE ADVANTAGES

—  
Innovative design with  
precision manufacturing.

—  
Providing reliability, efficiency  
and cost-effective solutions.

—  
Eliminate time consuming and  
costly manual processes.

—  
Significantly reduces the  
risk of mechanical failure or  
human error.

—  
Smart & Simple tool  
mechanism systems

—  
Strong and durable tools.

—  
Easy to use.

—  
Quick setup.

—  
Tools can work on variety of  
machines.

—  
The tools could work vertically  
and horizontally.

—  
The tools blade designed to  
protect the hole bore and to  
unarm the internal surface.

—  
The tools blade made from  
hardened HSS or CARBIDE  
and have high abrasion  
resistance.

—  
Custom made tools for your  
specific applications.

—  
Patent Pending.

# THE ULTIMATE SERIES

## 3 PRODUCT FAMILIES



### UBURR

**Deburring the front and back of a drilled through hole.**

UBurr deburring tools providing a quick, effective, reliable and consistent deburring way of front and back side bore edges of a drilled hole in one single pass

Efficient and convenient tools for long-term work and competitive price.

Ø3 mm up to Ø25 mm



### UCHAMF

**Back Chamfering of a drilled through hole.**

A sophisticated mechanism that allows a high level of accuracy to be achieved. The opening of the blade is done by opening and closing the coolant liquid from the machine.

Tools with a high level of accuracy and keeping competitive prices.

Ø8 mm up to Ø20 mm

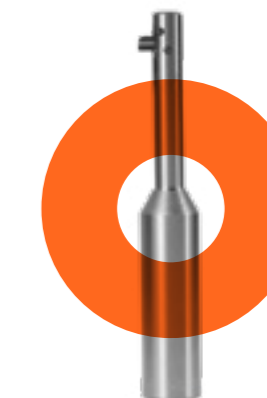

### USPOT

**Back Spotfacing of a drilled through hole.**

A sophisticated mechanism that allows a high level of accuracy to be achieved. The opening of the blade is done by opening and closing the coolant liquid from the machine.

Tools with a high level of accuracy and keeping competitive prices.

Ø8 mm up to Ø20 mm

★ Custom made tools available on request



# UBURR

## THE MACHINE DEBURRING TOOL

UBurr deburring tools provide you with an innovating way to remove your burrs.

UBurr deburring tools providing a quick, effective, reliable and consistent deburring way of front and back side bore edges of a drilled hole in one single pass.

A simple and efficient spring mechanism for inserting and removing the blade. Special blade sharpening that preserves the hole bore.

UBurr tools range remove burrs with an efficient and consistent way.

This solution is faster, easier, and more economical for your hole deburring problems for a mass production process.

UBurr deburring tool is a great choice for batch runs or in a production environment when a reliable and stable performance is required.

UBurr deburring tools radially removes the burrs off the bore edges, without requiring the workpiece to be turned or the spindle to be stopped.

The tool blade designed to easily deburr unwanted material from the front and back side of the holes in seconds.

The tool blade designed to protect the hole bore and to unarm the internal surface.

The UBurr standard tool series range from Ø3 mm up to Ø25mm.

Custom made tools can be made for your specific applications.



# UBURR

## NMT-UB

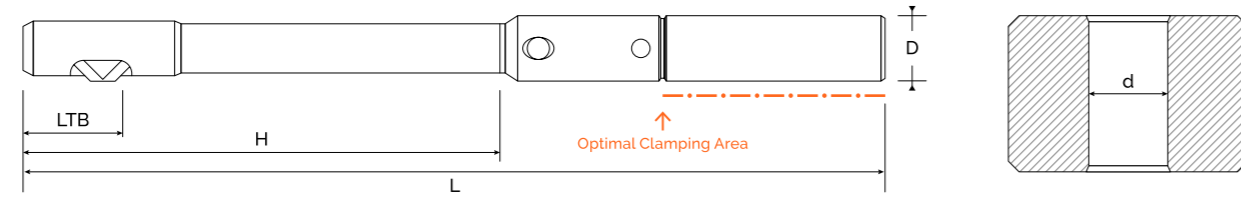

### ONE PASS SOLUTION TO HOLE-DEBURRING

Tool Item No.	Tool Description	Blade Item No.	Blade Description	Hole Diameter d	Shank Diameter D	LTB *	H	L
UB1030	NMT-UB-d030-H29-D08-L85	UB2030	NMT-UB-B 030 HSS	3.0	8.0	9.3	29.0	85.0
UB1032	NMT-UB-d032-H29-D08-L85	UB2032	NMT-UB-B 032 HSS	3.2	8.0	9.3	29.0	85.0
UB1034	NMT-UB-d034-H29-D08-L85	UB2034	NMT-UB-B 034 HSS	3.4	8.0	9.3	29.0	85.0
UB1035	NMT-UB-d035-H29-D08-L85	UB2035	NMT-UB-B 035 HSS	3.5	8.0	9.3	29.0	85.0
UB1036	NMT-UB-d036-H29-D08-L85	UB2036	NMT-UB-B 036 HSS	3.6	8.0	9.3	29.0	85.0
UB1038	NMT-UB-d038-H29-D08-L85	UB2038	NMT-UB-B 038 HSS	3.8	8.0	9.3	29.0	85.0
UB1040	NMT-UB-d040-H43-D08-L90	UB2040	NMT-UB-B 040 HSS	4.0	8.0	12.2	43.0	90.0
UB1042	NMT-UB-d042-H43-D08-L90	UB2042	NMT-UB-B 042 HSS	4.2	8.0	12.2	43.0	90.0
UB1044	NMT-UB-d044-H43-D08-L90	UB2044	NMT-UB-B 044 HSS	4.4	8.0	12.2	43.0	90.0
UB1045	NMT-UB-d045-H43-D08-L90	UB2045	NMT-UB-B 045 HSS	4.5	8.0	12.2	43.0	90.0
UB1046	NMT-UB-d046-H43-D08-L90	UB2046	NMT-UB-B 046 HSS	4.6	8.0	12.2	43.0	90.0
UB1048	NMT-UB-d048-H43-D08-L90	UB2048	NMT-UB-B 048 HSS	4.8	8.0	12.2	43.0	90.0
UB1050	NMT-UB-d050-H46-D08-L90	UB2050	NMT-UB-B 050 HSS	5.0	8.0	13.2	46.0	90.0
UB1052	NMT-UB-d052-H46-D08-L90	UB2052	NMT-UB-B 052 HSS	5.2	8.0	13.2	46.0	90.0
UB1054	NMT-UB-d054-H46-D08-L90	UB2054	NMT-UB-B 054 HSS	5.4	8.0	13.2	46.0	90.0
UB1055	NMT-UB-d055-H46-D08-L90	UB2055	NMT-UB-B 055 HSS	5.5	8.0	13.2	46.0	90.0
UB1056	NMT-UB-d056-H46-D08-L90	UB2056	NMT-UB-B 056 HSS	5.6	8.0	13.2	46.0	90.0
UB1058	NMT-UB-d058-H46-D08-L90	UB2058	NMT-UB-B 058 HSS	5.8	8.0	13.2	46.0	90.0
UB1060	NMT-UB-d060-H53-D08-L115	UB2060	NMT-UB-B 060-250 HSS	6.0	8.0	11.6	53.0	115.0
UB1062	NMT-UB-d062-H53-D08-L115	UB2060	NMT-UB-B 060-250 HSS	6.2	8.0	11.6	53.0	115.0

All measurements are in mm unless mentioned otherwise | \* Length to bottom

### TOOL DESIGNATION

NMT NOGA Machine Tools	UB - UBURR	d-Hole Diameter	H-Neck Down Length	D Shank Diameter	L Total Length
------------------------	------------	-----------------	--------------------	------------------	----------------

### BLADE/INSERT DESIGNATION

NMT NOGA Machine Tools	UB - B Blade/Insert	Blade/Insert Tool Dia	I/Angle	Blade Material&Coating
				HSS/HSS C(Coated)* * Upon Request

Tool Item No.	Tool Description	Blade Item No.	Blade Description	Hole Diameter d	Shank Diameter D	LTB *	H	L
UB1064	NMT-UB-d064-H53-D08-L115	UB2060	NMT-UB-B 060-250 HSS	6.4	8.0	11.6	53.0	115.0
UB1065	NMT-UB-d065-H53-D08-L115	UB2060	NMT-UB-B 060-250 HSS	6.5	8.0	11.6	53.0	115.0
UB1066	NMT-UB-d066-H53-D08-L115	UB2060	NMT-UB-B 060-250 HSS	6.6	8.0	11.6	53.0	115.0
UB1068	NMT-UB-d068-H53-D08-L115	UB2060	NMT-UB-B 060-250 HSS	6.8	8.0	11.6	53.0	115.0
UB1070	NMT-UB-d070-H53-D10-L115	UB2060	NMT-UB-B 060-250 HSS	7.0	10.0	11.6	53.0	115.0
UB1072	NMT-UB-d072-H53-D10-L115	UB2060	NMT-UB-B 060-250 HSS	7.2	10.0	11.6	53.0	115.0
UB1074	NMT-UB-d074-H53-D10-L115	UB2060	NMT-UB-B 060-250 HSS	7.4	10.0	11.6	53.0	115.0
UB1075	NMT-UB-d075-H53-D10-L115	UB2060	NMT-UB-B 060-250 HSS	7.5	10.0	11.6	53.0	115.0
UB1076	NMT-UB-d076-H53-D10-L115	UB2060	NMT-UB-B 060-250 HSS	7.6	10.0	11.6	53.0	115.0
UB1078	NMT-UB-d078-H53-D10-L115	UB2060	NMT-UB-B 060-250 HSS	7.8	10.0	11.6	53.0	115.0
UB1080	NMT-UB-d080-H53-D10-L115	UB2060	NMT-UB-B 060-250 HSS	8.0	10.0	11.6	53.0	115.0
UB1082	NMT-UB-d082-H53-D10-L115	UB2060	NMT-UB-B 060-250 HSS	8.2	10.0	11.6	53.0	115.0
UB1084	NMT-UB-d084-H53-D10-L115	UB2060	NMT-UB-B 060-250 HSS	8.4	10.0	11.6	53.0	115.0
UB1085	NMT-UB-d085-H53-D10-L115	UB2060	NMT-UB-B 060-250 HSS	8.5	10.0	11.6	53.0	115.0
UB1086	NMT-UB-d086-H53-D10-L115	UB2060	NMT-UB-B 060-250 HSS	8.6	10.0	11.6	53.0	115.0
UB1088	NMT-UB-d088-H53-D10-L115	UB2060	NMT-UB-B 060-250 HSS	8.8	10.0	11.6	53.0	115.0
UB1090	NMT-UB-d090-H53-D10-L115	UB2060	NMT-UB-B 060-250 HSS	9.0	10.0	11.6	53.0	115.0
UB1092	NMT-UB-d092-H53-D10-L115	UB2060	NMT-UB-B 060-250 HSS	9.2	10.0	11.6	53.0	115.0
UB1094	NMT-UB-d094-H53-D10-L115	UB2060	NMT-UB-B 060-250 HSS	9.4	10.0	11.6	53.0	115.0
UB1095	NMT-UB-d095-H53-D10-L115	UB2060	NMT-UB-B 060-250 HSS	9.5	10.0	11.6	53.0	115.0

All measurements are in mm unless mentioned otherwise | \* Length to bottom

# UBURR NMT-UB

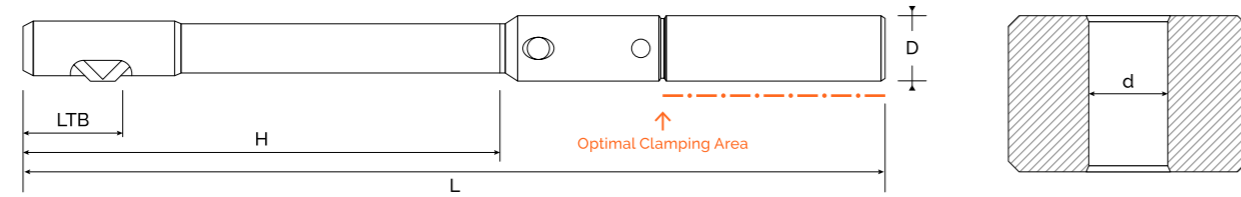

## ONE PASS SOLUTION TO HOLE-DEBURRING

Tool Item No.	Tool Description	Blade Item No.	Blade Description	Hole Diameter d	Shank Diameter D	LTB *	H	L
UB1096	NMT-UB-d096-H53-D10-L115	UB2060	NMT-UB-B 060-250 HSS	9.6	10.0	11.6	53.0	115.0
UB1098	NMT-UB-d098-H53-D10-L115	UB2060	NMT-UB-B 060-250 HSS	9.8	10.0	11.6	53.0	115.0
UB1100	NMT-UB-d100-H119-D10-L165	UB2060	NMT-UB-B 060-250 HSS	10.0	10.0	13.3	119.0	165.0
UB1102	NMT-UB-d102-H119-D10-L165	UB2060	NMT-UB-B 060-250 HSS	10.2	10.0	13.3	119.0	165.0
UB1104	NMT-UB-d104-H119-D10-L165	UB2060	NMT-UB-B 060-250 HSS	10.4	10.0	13.3	119.0	165.0
UB1105	NMT-UB-d105-H119-D10-L165	UB2060	NMT-UB-B 060-250 HSS	10.5	10.0	13.3	119.0	165.0
UB1106	NMT-UB-d106-H119-D10-L165	UB2060	NMT-UB-B 060-250 HSS	10.6	10.0	13.3	119.0	165.0
UB1108	NMT-UB-d108-H119-D10-L165	UB2060	NMT-UB-B 060-250 HSS	10.8	10.0	13.3	119.0	165.0
UB1110	NMT-UB-d110-H119-D10-L165	UB2060	NMT-UB-B 060-250 HSS	11.0	10.0	13.3	119.0	165.0
UB1112	NMT-UB-d112-H119-D10-L165	UB2060	NMT-UB-B 060-250 HSS	11.2	10.0	13.3	119.0	165.0
UB1114	NMT-UB-d114-H119-D10-L165	UB2060	NMT-UB-B 060-250 HSS	11.4	10.0	13.3	119.0	165.0
UB1115	NMT-UB-d115-H119-D10-L165	UB2060	NMT-UB-B 060-250 HSS	11.5	10.0	13.3	119.0	165.0
UB1116	NMT-UB-d116-H119-D10-L165	UB2060	NMT-UB-B 060-250 HSS	11.6	10.0	13.3	119.0	165.0
UB1118	NMT-UB-d118-H119-D10-L165	UB2060	NMT-UB-B 060-250 HSS	11.8	10.0	13.3	119.0	165.0
UB1120	NMT-UB-d120-H119-D12-L165	UB2060	NMT-UB-B 060-250 HSS	12.0	12.0	13.3	119.0	165.0
UB1122	NMT-UB-d122-H119-D12-L165	UB2060	NMT-UB-B 060-250 HSS	12.2	12.0	13.3	119.0	165.0
UB1124	NMT-UB-d124-H119-D12-L165	UB2060	NMT-UB-B 060-250 HSS	12.4	12.0	13.3	119.0	165.0
UB1125	NMT-UB-d125-H119-D12-L165	UB2060	NMT-UB-B 060-250 HSS	12.5	12.0	13.3	119.0	165.0
UB1126	NMT-UB-d126-H119-D12-L165	UB2060	NMT-UB-B 060-250 HSS	12.6	12.0	13.3	119.0	165.0
UB1128	NMT-UB-d128-H119-D12-L165	UB2060	NMT-UB-B 060-250 HSS	12.8	12.0	13.3	119.0	165.0

All measurements are in mm unless mentioned otherwise | \* Length to bottom

## TOOL DESIGNATION

NMT NOGA Machine Tools	UB - UBURR	d-Hole Diameter	H-Neck Down Length	D Shank Diameter	L Total Length
---------------------------	------------	-----------------	--------------------	------------------	----------------

## BLADE/INSERT DESIGNATION

NMT NOGA Machine Tools	UB - B Blade/Insert	Blade/Insert Tool Dia	I/Angle	Blade Material&Coating
				HSS/HSS C(Coated)* * Upon Request

Tool Item No.	Tool Description	Blade Item No.	Blade Description	Hole Diameter d	Shank Diameter D	LTB *	H	L
UB1130	NMT-UB-d130-H119-D12-L165	UB2060	NMT-UB-B 060-250 HSS	13.0	12.0	13.3	119.0	165.0
UB1132	NMT-UB-d132-H119-D12-L165	UB2060	NMT-UB-B 060-250 HSS	13.2	12.0	13.3	119.0	165.0
UB1134	NMT-UB-d134-H119-D12-L165	UB2060	NMT-UB-B 060-250 HSS	13.4	12.0	13.3	119.0	165.0
UB1135	NMT-UB-d135-H119-D12-L165	UB2060	NMT-UB-B 060-250 HSS	13.5	12.0	13.3	119.0	165.0
UB1136	NMT-UB-d136-H119-D12-L165	UB2060	NMT-UB-B 060-250 HSS	13.6	12.0	13.3	119.0	165.0
UB1138	NMT-UB-d138-H119-D12-L165	UB2060	NMT-UB-B 060-250 HSS	13.8	12.0	13.3	119.0	165.0
UB1140	NMT-UB-d140-H119-D12-L165	UB2060	NMT-UB-B 060-250 HSS	14.0	12.0	13.3	119.0	165.0
UB1142	NMT-UB-d142-H119-D12-L165	UB2060	NMT-UB-B 060-250 HSS	14.2	12.0	13.3	119.0	165.0
UB1144	NMT-UB-d144-H119-D12-L165	UB2060	NMT-UB-B 060-250 HSS	14.4	12.0	13.3	119.0	165.0
UB1145	NMT-UB-d145-H119-D12-L165	UB2060	NMT-UB-B 060-250 HSS	14.5	12.0	13.3	119.0	165.0
UB1146	NMT-UB-d146-H119-D12-L165	UB2060	NMT-UB-B 060-250 HSS	14.6	12.0	13.3	119.0	165.0
UB1148	NMT-UB-d148-H119-D12-L165	UB2060	NMT-UB-B 060-250 HSS	14.8	12.0	13.3	119.0	165.0
UB1150	NMT-UB-d150-H119-D12-L165	UB2060	NMT-UB-B 060-250 HSS	15.0	12.0	13.3	119.0	165.0
UB1152	NMT-UB-d152-H119-D12-L165	UB2060	NMT-UB-B 060-250 HSS	15.2	12.0	13.3	119.0	165.0
UB1154	NMT-UB-d154-H119-D12-L165	UB2060	NMT-UB-B 060-250 HSS	15.4	12.0	13.3	119.0	165.0
UB1155	NMT-UB-d155-H119-D12-L165	UB2060	NMT-UB-B 060-250 HSS	15.5	12.0	13.3	119.0	165.0
UB1156	NMT-UB-d156-H119-D12-L165	UB2060	NMT-UB-B 060-250 HSS	15.6	12.0	13.3	119.0	165.0
UB1158	NMT-UB-d158-H119-D12-L165	UB2060	NMT-UB-B 060-250 HSS	15.8	12.0	13.3	119.0	165.0
UB1160	NMT-UB-d160-H119-D12-L165	UB2060	NMT-UB-B 060-250 HSS	16.0	12.0	13.3	119.0	165.0
UB1162	NMT-UB-d162-H119-D12-L165	UB2060	NMT-UB-B 060-250 HSS	16.2	12.0	13.3	119.0	165.0

All measurements are in mm unless mentioned otherwise | \* Length to bottom

# UBURR

## NMT-UB

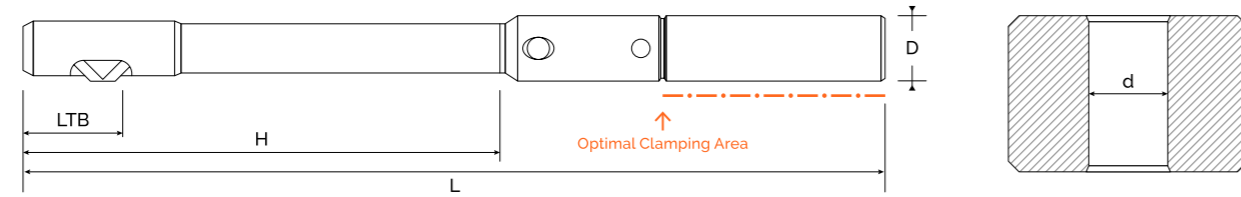

### ONE PASS SOLUTION TO HOLE-DEBURRING

Tool Item No.	Tool Description	Blade Item No.	Blade Description	Hole Diameter d	Shank Diameter D	LTB *	H	L
UB1164	NMT-UB-d164-H119-D12-L165	UB2060	NMT-UB-B 060-250 HSS	16.4	12.0	13.3	119.0	165.0
UB1165	NMT-UB-d165-H119-D12-L165	UB2060	NMT-UB-B 060-250 HSS	16.5	12.0	13.3	119.0	165.0
UB1166	NMT-UB-d166-H119-D12-L165	UB2060	NMT-UB-B 060-250 HSS	16.6	12.0	13.3	119.0	165.0
UB1168	NMT-UB-d168-H119-D12-L165	UB2060	NMT-UB-B 060-250 HSS	16.8	12.0	13.3	119.0	165.0
UB1170	NMT-UB-d170-H119-D12-L165	UB2060	NMT-UB-B 060-250 HSS	17.0	12.0	13.3	119.0	165.0
UB1172	NMT-UB-d172-H119-D12-L165	UB2060	NMT-UB-B 060-250 HSS	17.2	12.0	13.3	119.0	165.0
UB1174	NMT-UB-d174-H119-D12-L165	UB2060	NMT-UB-B 060-250 HSS	17.4	12.0	13.3	119.0	165.0
UB1175	NMT-UB-d175-H119-D12-L165	UB2060	NMT-UB-B 060-250 HSS	17.5	12.0	13.3	119.0	165.0
UB1176	NMT-UB-d176-H119-D12-L165	UB2060	NMT-UB-B 060-250 HSS	17.6	12.0	13.3	119.0	165.0
UB1178	NMT-UB-d178-H119-D12-L165	UB2060	NMT-UB-B 060-250 HSS	17.8	12.0	13.3	119.0	165.0
UB1180	NMT-UB-d180-H119-D12-L165	UB2060	NMT-UB-B 060-250 HSS	18.0	12.0	13.3	119.0	165.0
UB1182	NMT-UB-d182-H119-D12-L165	UB2060	NMT-UB-B 060-250 HSS	18.2	12.0	13.3	119.0	165.0
UB1184	NMT-UB-d184-H119-D12-L165	UB2060	NMT-UB-B 060-250 HSS	18.4	12.0	13.3	119.0	165.0
UB1185	NMT-UB-d185-H119-D12-L165	UB2060	NMT-UB-B 060-250 HSS	18.5	12.0	13.3	119.0	165.0
UB1186	NMT-UB-d186-H119-D12-L165	UB2060	NMT-UB-B 060-250 HSS	18.6	12.0	13.3	119.0	165.0
UB1188	NMT-UB-d188-H119-D12-L165	UB2060	NMT-UB-B 060-250 HSS	18.8	12.0	13.3	119.0	165.0
UB1190	NMT-UB-d190-H119-D12-L165	UB2060	NMT-UB-B 060-250 HSS	19.0	12.0	13.3	119.0	165.0
UB1192	NMT-UB-d192-H119-D12-L165	UB2060	NMT-UB-B 060-250 HSS	19.2	12.0	13.3	119.0	165.0
UB1194	NMT-UB-d194-H119-D12-L165	UB2060	NMT-UB-B 060-250 HSS	19.4	12.0	13.3	119.0	165.0
UB1195	NMT-UB-d195-H119-D12-L165	UB2060	NMT-UB-B 060-250 HSS	19.5	12.0	13.3	119.0	165.0

All measurements are in mm unless mentioned otherwise | \* Length to bottom

### TOOL DESIGNATION

NMT NOGA Machine Tools	UB - UBURR	d-Hole Diameter	H-Neck Down Length	D Shank Diameter	L Total Length
------------------------	------------	-----------------	--------------------	------------------	----------------

### BLADE/INSERT DESIGNATION

NMT NOGA Machine Tools	UB - B Blade/Insert	Blade/Insert Tool Dia	I/Angle	Blade Material&Coating
				HSS/HSS C(Coated)* * Upon Request

Tool Item No.	Tool Description	Blade Item No.	Blade Description	Hole Diameter d	Shank Diameter D	LTB *	H	L
UB1196	NMT-UB-d196-H119-D12-L165	UB2060	NMT-UB-B 060-250 HSS	19.6	12.0	13.3	119.0	165.0
UB1198	NMT-UB-d198-H119-D12-L165	UB2060	NMT-UB-B 060-250 HSS	19.8	12.0	13.3	119.0	165.0
UB1200	NMT-UB-d200-H119-D12-L165	UB2060	NMT-UB-B 060-250 HSS	20.0	12.0	13.3	119.0	165.0
UB1202	NMT-UB-d202-H119-D12-L165	UB2060	NMT-UB-B 060-250 HSS	20.2	12.0	13.3	119.0	165.0
UB1204	NMT-UB-d204-H119-D12-L165	UB2060	NMT-UB-B 060-250 HSS	20.4	12.0	13.3	119.0	165.0
UB1205	NMT-UB-d205-H119-D12-L165	UB2060	NMT-UB-B 060-250 HSS	20.5	12.0	13.3	119.0	165.0
UB1206	NMT-UB-d206-H119-D12-L165	UB2060	NMT-UB-B 060-250 HSS	20.6	12.0	13.3	119.0	165.0
UB1208	NMT-UB-d208-H119-D12-L165	UB2060	NMT-UB-B 060-250 HSS	20.8	12.0	13.3	119.0	165.0
UB1210	NMT-UB-d210-H119-D12-L165	UB2060	NMT-UB-B 060-250 HSS	21.0	12.0	13.3	119.0	165.0
UB1212	NMT-UB-d212-H119-D12-L165	UB2060	NMT-UB-B 060-250 HSS	21.2	12.0	13.3	119.0	165.0
UB1214	NMT-UB-d214-H119-D12-L165	UB2060	NMT-UB-B 060-250 HSS	21.4	12.0	13.3	119.0	165.0
UB1215	NMT-UB-d215-H119-D12-L165	UB2060	NMT-UB-B 060-250 HSS	21.5	12.0	13.3	119.0	165.0
UB1216	NMT-UB-d216-H119-D12-L165	UB2060	NMT-UB-B 060-250 HSS	21.6	12.0	13.3	119.0	165.0
UB1218	NMT-UB-d218-H119-D12-L165	UB2060	NMT-UB-B 060-250 HSS	21.8	12.0	13.3	119.0	165.0
UB1220	NMT-UB-d220-H119-D12-L165	UB2060	NMT-UB-B 060-250 HSS	22.0	12.0	13.3	119.0	165.0
UB1222	NMT-UB-d222-H119-D12-L165	UB2060	NMT-UB-B 060-250 HSS	22.2	12.0	13.3	119.0	165.0
UB1224	NMT-UB-d224-H119-D12-L165	UB2060	NMT-UB-B 060-250 HSS	22.4	12.0	13.3	119.0	165.0
UB1225	NMT-UB-d225-H119-D12-L165	UB2060	NMT-UB-B 060-250 HSS	22.5	12.0	13.3	119.0	165.0
UB1226	NMT-UB-d226-H119-D12-L165	UB2060	NMT-UB-B 060-250 HSS	22.6	12.0	13.3	119.0	165.0
UB1228	NMT-UB-d228-H119-D12-L165	UB2060	NMT-UB-B 060-250 HSS	22.8	12.0	13.3	119.0	165.0

All measurements are in mm unless mentioned otherwise | \* Length to bottom



# UBURR

## NMT-UB

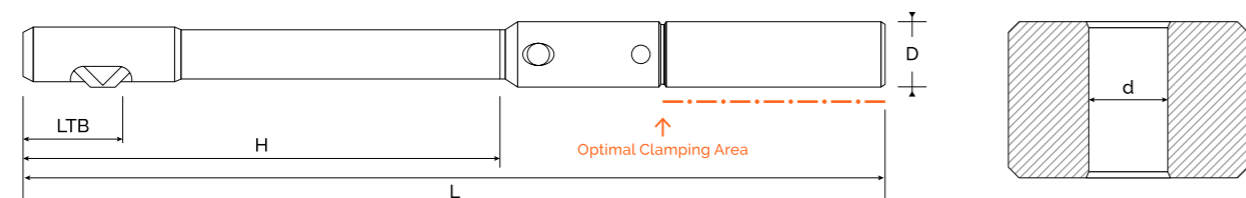

### ONE PASS SOLUTION TO HOLE-DEBURRING

#### TOOL DESIGNATION

NMT NOGA Machine Tools	UB - UBURR	d-Hole Diameter	H-Neck Down Length	D Shank Diameter	L Total Length
---------------------------	------------	-----------------	--------------------	------------------	----------------

#### BLADE/INSERT DESIGNATION

NMT NOGA Machine Tools	UB - B Blade/Insert	Blade/Insert Tool Dia	I/Angle	Blade Material&Coating
				HSS/HSS C(Coated)* * Upon Request

Tool Item No.	Tool Description	Blade Item No.	Blade Description	Hole Diameter d	Shank Diameter D	LTB *	H	L
UB1230	NMT-UB-d230-H119-D12-L165	UB2060	NMT-UB-B 060-250 HSS	23.0	12.0	13.3	119.0	165.0
UB1232	NMT-UB-d232-H119-D12-L165	UB2060	NMT-UB-B 060-250 HSS	23.2	12.0	13.3	119.0	165.0
UB1234	NMT-UB-d234-H119-D12-L165	UB2060	NMT-UB-B 060-250 HSS	23.4	12.0	13.3	119.0	165.0
UB1235	NMT-UB-d235-H119-D12-L165	UB2060	NMT-UB-B 060-250 HSS	23.5	12.0	13.3	119.0	165.0
UB1236	NMT-UB-d236-H119-D12-L165	UB2060	NMT-UB-B 060-250 HSS	23.6	12.0	13.3	119.0	165.0
UB1238	NMT-UB-d238-H119-D12-L165	UB2060	NMT-UB-B 060-250 HSS	23.8	12.0	13.3	119.0	165.0
UB1240	NMT-UB-d240-H119-D12-L165	UB2060	NMT-UB-B 060-250 HSS	24.0	12.0	13.3	119.0	165.0
UB1242	NMT-UB-d242-H119-D12-L165	UB2060	NMT-UB-B 060-250 HSS	24.2	12.0	13.3	119.0	165.0
UB1244	NMT-UB-d244-H119-D12-L165	UB2060	NMT-UB-B 060-250 HSS	24.4	12.0	13.3	119.0	165.0
UB1245	NMT-UB-d245-H119-D12-L165	UB2060	NMT-UB-B 060-250 HSS	24.5	12.0	13.3	119.0	165.0
UB1246	NMT-UB-d246-H119-D12-L165	UB2060	NMT-UB-B 060-250 HSS	24.6	12.0	13.3	119.0	165.0
UB1248	NMT-UB-d248-H119-D12-L165	UB2060	NMT-UB-B 060-250 HSS	24.8	12.0	13.3	119.0	165.0
UB1250	NMT-UB-d250-H119-D12-L165	UB2060	NMT-UB-B 060-250 HSS	25.0	12.0	13.3	119.0	165.0

All measurements are in mm unless mentioned otherwise | \* Length to bottom

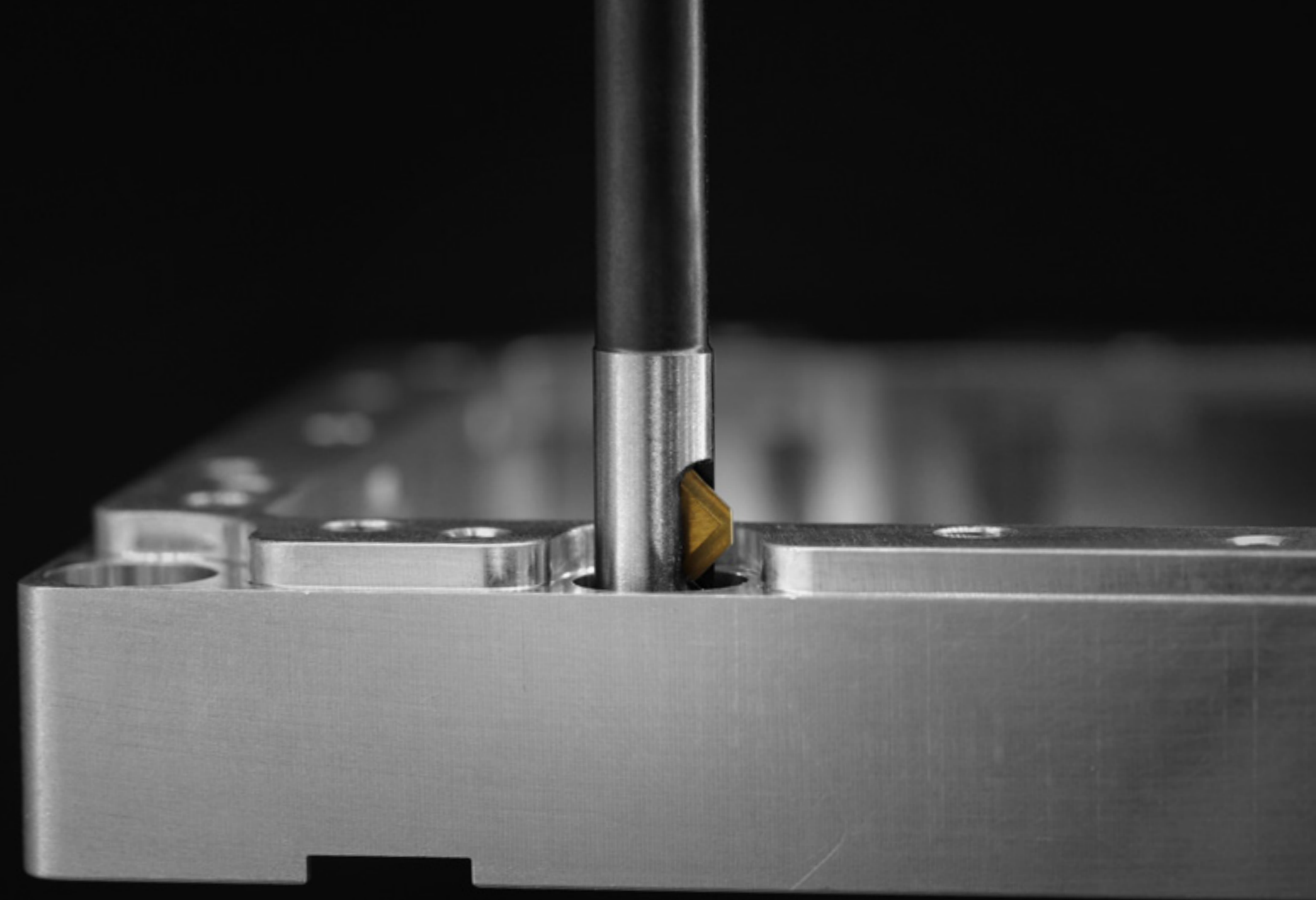

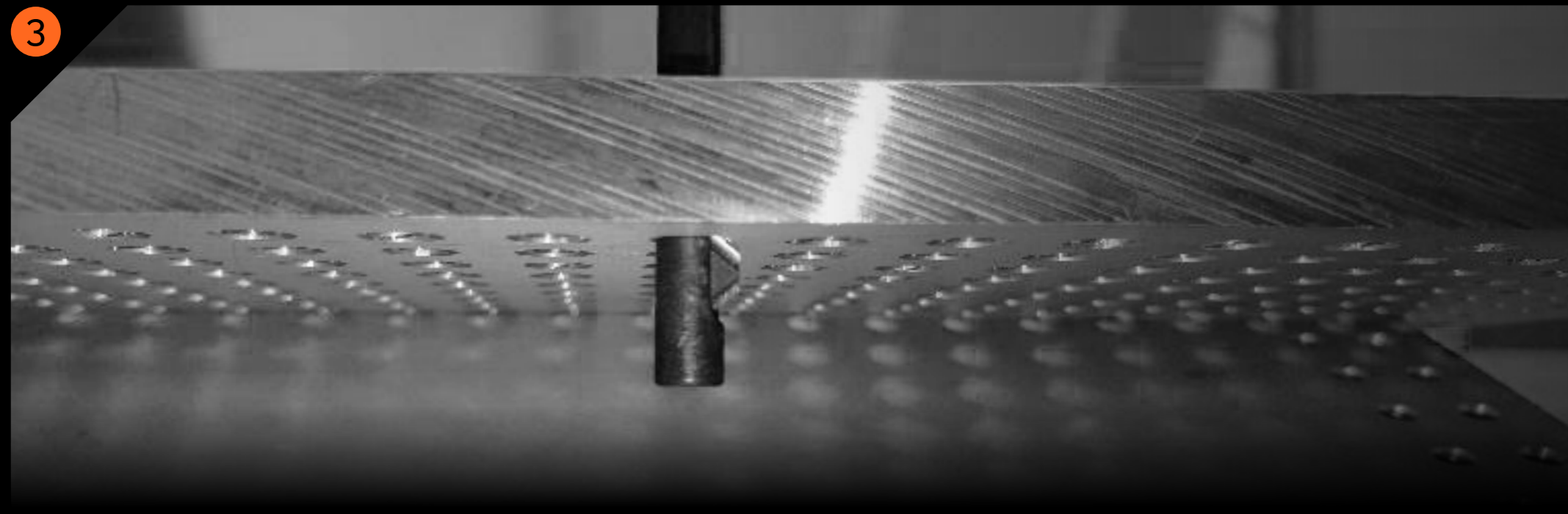
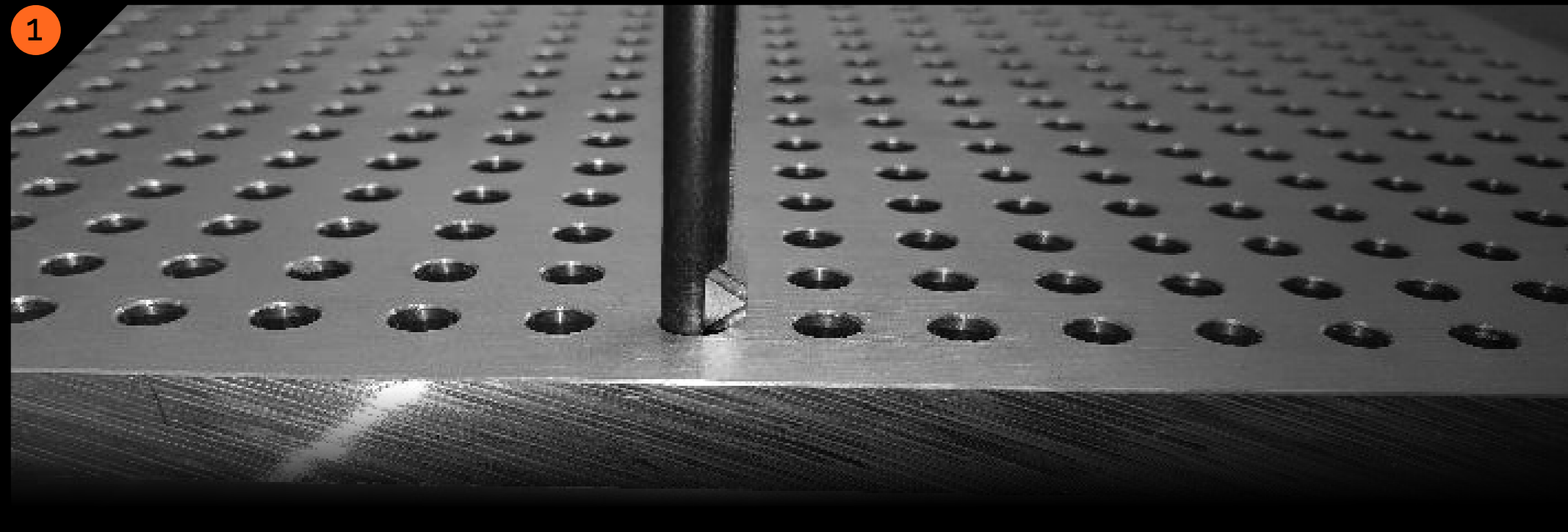

# UBURR: THE TOOL PATH

## ONE PASS SOLUTION TO HOLE-DEBURRING

1

**UBURR** tools remove the burr from the front hole surface by a unique flexible blade.

2

The **UBURR** blade enters into the tool pocket automatically as the pressure is increasing on the blade.

The unique geometry prevents the blade to damage the surface inside the hole.

3

The **UBURR** tools remove the burr from the back hole surface with the same spindle direction by going up.

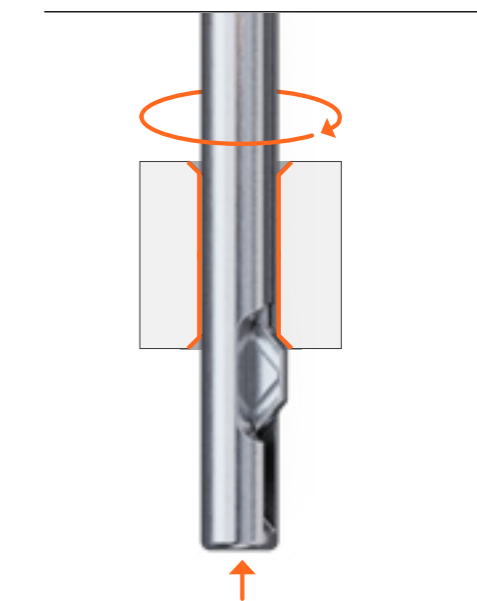
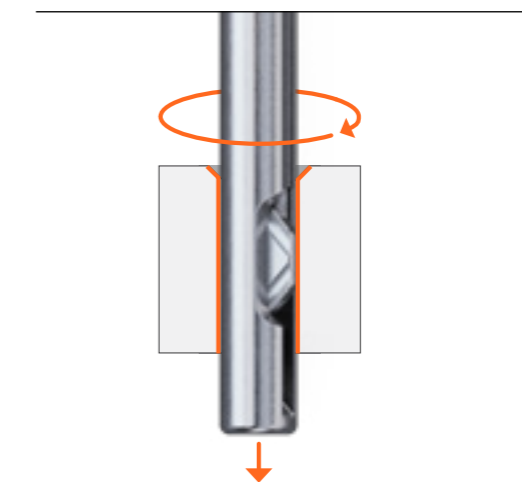
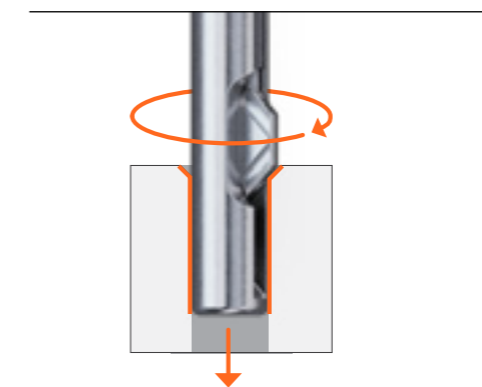

# UBURR

ONE PASS SOLUTION  
TO HOLE-DEBURRING



## CUTTING CONDITIONS

### UBURR

		HSS		HSS + COATING TiN	
		Vc=m/min	Fz=mm/tooth	Vc=m/min	Fz=mm/tooth
<b>P</b>	Steel	25.0-45.0	0.05-0.1	45.0-65.0	0.05-0.1
<b>M</b>	Stainless Steel	15.0-30.0	0.05-0.08	30.0-55.0	0.05-0.08
<b>K</b>	Cast Iron	20.0-35.0	0.05-0.1	35.0-55.0	0.05-0.1
<b>N</b>	Aluminum	40.0-60.0	0.05-0.12	50.0-75.0	0.05-0.12
<b>S</b>	Titanium / Inconel	10.0-15.0	0.05-0.08	15.0-20.0	0.05-0.08
<b>H</b>	Hard Material	15.0-30.0	0.05-0.08	20.0-35.0	0.05-0.08

# BLADE INSERTION **UBURR**

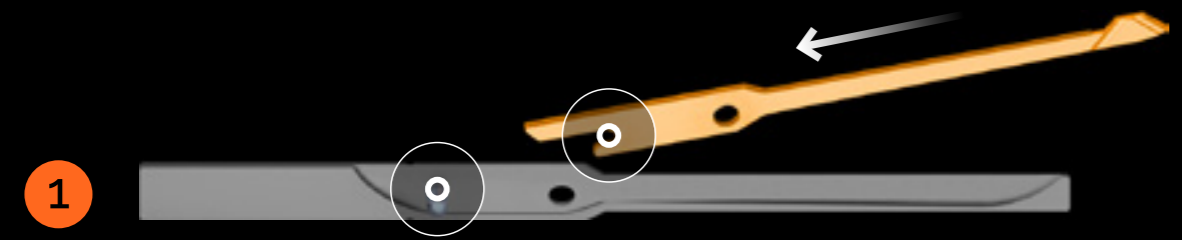

Insert the blade into the holder slot until the blade stops at the holder pin.



Push the blade into the tool pocket.

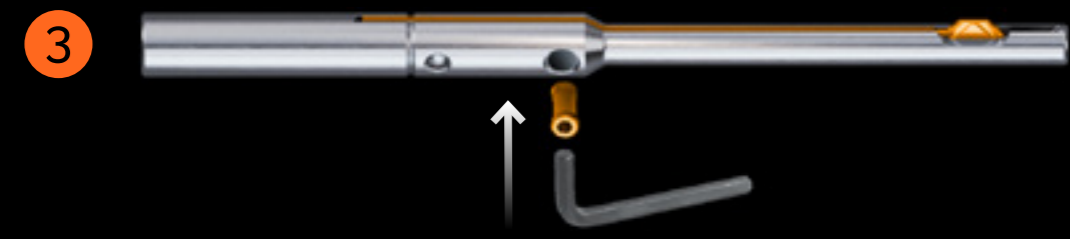

Lock the screw clockwise.

# BLADE REMOVAL **UBURR**

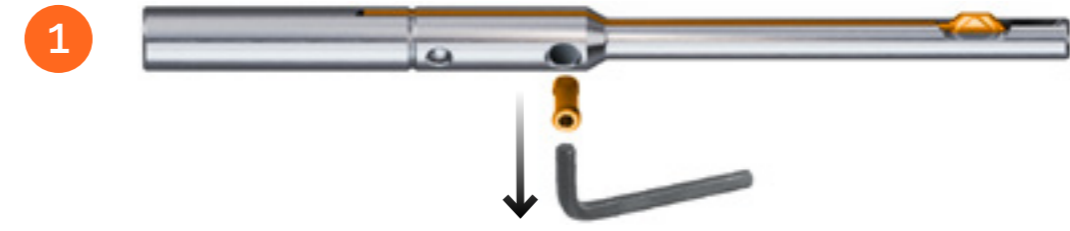

Remove the blade: Unlock the screw with Allen Key counterclockwise turn of the locking screw.



Push the blade by hexagon key through the technical hole.



Pull up the blade from the holder.



# U**CHAMF**

## THE MACHINE BACK CHAMFERING TOOL

UChamf tools allow back chamfering with an efficient and consistent way.

UChamf tools allow back chamfering through holes in one operation without turning the workpiece.

UChamf tools are focused on the reliability of the solutions.

This solution is faster, easier, and more economical for your back chamfering problems for a mass production process.

The UChamf tool is especially designed for automatic operation.

The opening and closing of the blade are controlled by activating the internal coolant of the machine.

The tool blade designed to protect the hole bore and to unarm the internal surface.

The UChamf standard tool series range from Ø8 mm up to Ø20 mm. The tool is available in different chamfer angles and sizes.

Custom made tools can be made for your specific applications.



# UCHAMF

## NMT-UC

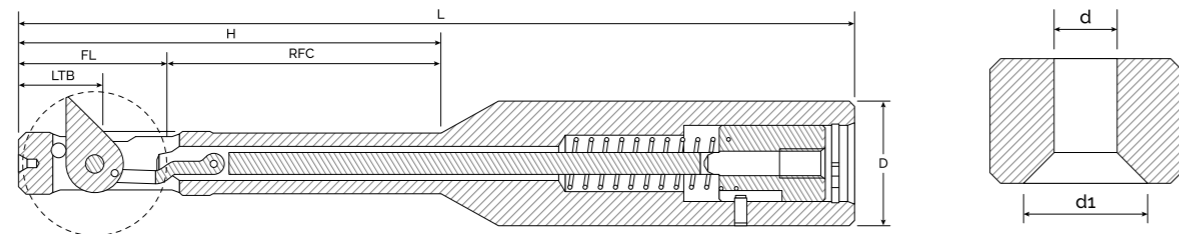

### ONE PASS SOLUTION TO THROUGH-HOLE: BACK CHAMFERING

Tool Item No.	Tool Description	Bore Ød	Bore Ød1 Range	LTB*	RFC**	FL***	H	D	L	Blade Item No.	Blade 45°
UC1080	NMT-UC-d080-H40-D16-L114	8.0	8.1-18.5	11.0	40.0	19.0	59.0	16.0	114.0	UC2080	NMT-US-B-080 I18.5 /45 HSS
UC1085	NMT-UC-d085-H40-D16-L114	8.5	8.6-19.0	11.0	40.0	19.0	59.0	16.0	114.0	UC2085	NMT-US-B-085 I19.0 /45 HSS
UC1090	NMT-UC-d090-H40-D16-L114	9.0	9.1-20.0	11.0	40.0	19.0	59.0	16.0	114.0	UC2090	NMT-US-B-090 I20.0 /45 HSS
UC1095	NMT-UC-d095-H40-D16-L114	9.5	9.6-20.5	11.0	40.0	19.0	59.0	16.0	114.0	UC2095	NMT-US-B-095 I20.5 /45 HSS
UC1100	NMT-UC-d100-H50-D16-L125	10.0	10.1-23.0	12.5	50.0	22.5	72.5	16.0	125.0	UC2100	NMT-US-B-100 I23.0 /45 HSS
UC1105	NMT-UC-d105-H50-D16-L125	10.5	10.6-23.5	12.5	50.0	22.5	72.5	16.0	125.0	UC2105	NMT-US-B-105 I23.5 /45 HSS
UC1110	NMT-UC-d110-H50-D16-L125	11.0	11.1-25.0	12.5	50.0	22.5	72.5	16.0	125.0	UC2110	NMT-US-B-110 I25.0 /45 HSS
UC1115	NMT-UC-d115-H50-D16-L125	11.5	11.5-25.5	12.5	50.0	22.5	72.5	16.0	125.0	UC2115	NMT-US-B-115 I25.5 /45 HSS
UC1120	NMT-UC-d120-H50-D16-L125	12.0	12.1-27.5	13.8	50.0	25.5	75.5	16.0	125.0	UC2120	NMT-US-B-120 I27.5 /45 HSS
UC1125	NMT-UC-d125-H50-D16-L125	12.5	12.6-28.0	13.8	50.0	25.5	75.5	16.0	125.0	UC2125	NMT-US-B-125 I28.0 /45 HSS
UC1130	NMT-UC-d130-H50-D16-L125	13.0	13.1-30.0	13.8	50.0	25.5	75.5	16.0	125.0	UC2130	NMT-US-B-130 I30.0 /45 HSS
UC1135	NMT-UC-d135-H50-D16-L125	13.5	13.6-30.5	13.8	50.0	25.5	75.5	16.0	125.0	UC2135	NMT-US-B-135 I30.5 /45 HSS
UC1140	NMT-UC-d140-H50-D16-L125	14.0	14.1-32.0	15.0	50.0	29.0	79.0	16.0	125.0	UC2140	NMT-US-B-140 I32.0 /45 HSS

All measurements are in mm unless mentioned otherwise | \* Length to bottom | \*\* Relief for cutting | \*\*\* Folding Length

### TOOL DESIGNATION

NMT NOGA  
Machine Tools

UC - UHAMF

### BLADE/INSERT DESIGNATION

NMT NOGA  
Machine Tools

UC - B

### I/Angle

Cutting Length/Angle

### Blade Material & Coating

HSS / HSS C(coated)\*  
or CR / CRC\* (CA (Carbide/CAC) Carbide Coated)\*

\* Upon Request

Tool Item No.	Tool Description	Bore Ød	Bore Ød1 Range	LTB*	RFC**	FL***	H	D	L	Blade Item No.	Blade 45°
UC1145	NMT-UC-d145-H50-D16-L125	14.5	14.6-32.5	15.0	50.0	29.0	79.0	16.0	125.0	UC2145	NMT-US-B-145 I32.5 /45 HSS
UC1150	NMT-UC-d150-H70-D16-L150	15.0	15.1-34.5	15.0	70.0	29.0	99.0	16.0	150.0	UC2150	NMT-US-B-150 I34.5 /45 HSS
UC1155	NMT-UC-d155-H70-D16-L150	15.5	15.6-35.0	15.0	70.0	29.0	99.0	16.0	150.0	UC2155	NMT-US-B-155 I35.0 /45 HSS
UC1160	NMT-UC-d160-H70-D16-L160	16.0	16.1-37.0	18.4	70.0	34.0	104.0	16.0	160.0	UC2160	NMT-US-B-160 I37.0 /45 HSS
UC1165	NMT-UC-d165-H70-D20-L160	16.5	16.6-37.5	18.4	70.0	34.0	104.0	16.0	160.0	UC2165	NMT-US-B-165 I37.5 /45 HSS
UC1170	NMT-UC-d170-H70-D20-L160	17.0	17.1-39.0	18.4	70.0	34.0	104.0	20.0	160.0	UC2170	NMT-US-B-170 I39.0 /45 HSS
UC1175	NMT-UC-d175-H70-D20-L160	17.5	17.6-39.5	18.4	70.0	34.0	104.0	20.0	160.0	UC2175	NMT-US-B-175 I39.5 /45 HSS
UC1180	NMT-UC-d180-H70-D20-L160	18.0	18.1-41.0	20.4	70.0	37.5	107.5	20.0	160.0	UC2180	NMT-US-B-180 I41.0 /45 HSS
UC1185	NMT-UC-d185-H70-D20-L160	18.5	18.6-41.5	20.4	70.0	37.5	107.5	20.0	160.0	UC2185	NMT-US-B-185 I41.5 /45 HSS
UC1190	NMT-UC-d195-H70-D20-L160	19.0	19.1-43.5	20.4	70.0	37.5	107.5	20.0	160.0	UC2190	NMT-US-B-190 I43.5 /45 HSS
UC1195	NMT-UC-d195-H70-D20-L160	19.5	19.4-44.0	20.4	70.0	37.5	107.5	20.0	160.0	UC2195	NMT-US-B-195 I44.0 /45 HSS
UC1200	NMT-UC-d200-H70-D20-L168	20.0	20.1-46.0	20.4	70.0	38.0	108.0	20.0	170.0	UC2200	NMT-US-B-200 I46.0 /45 HSS

All measurements are in mm unless mentioned otherwise | \* Length to bottom | \*\* Relief for cutting | \*\*\* Folding Length

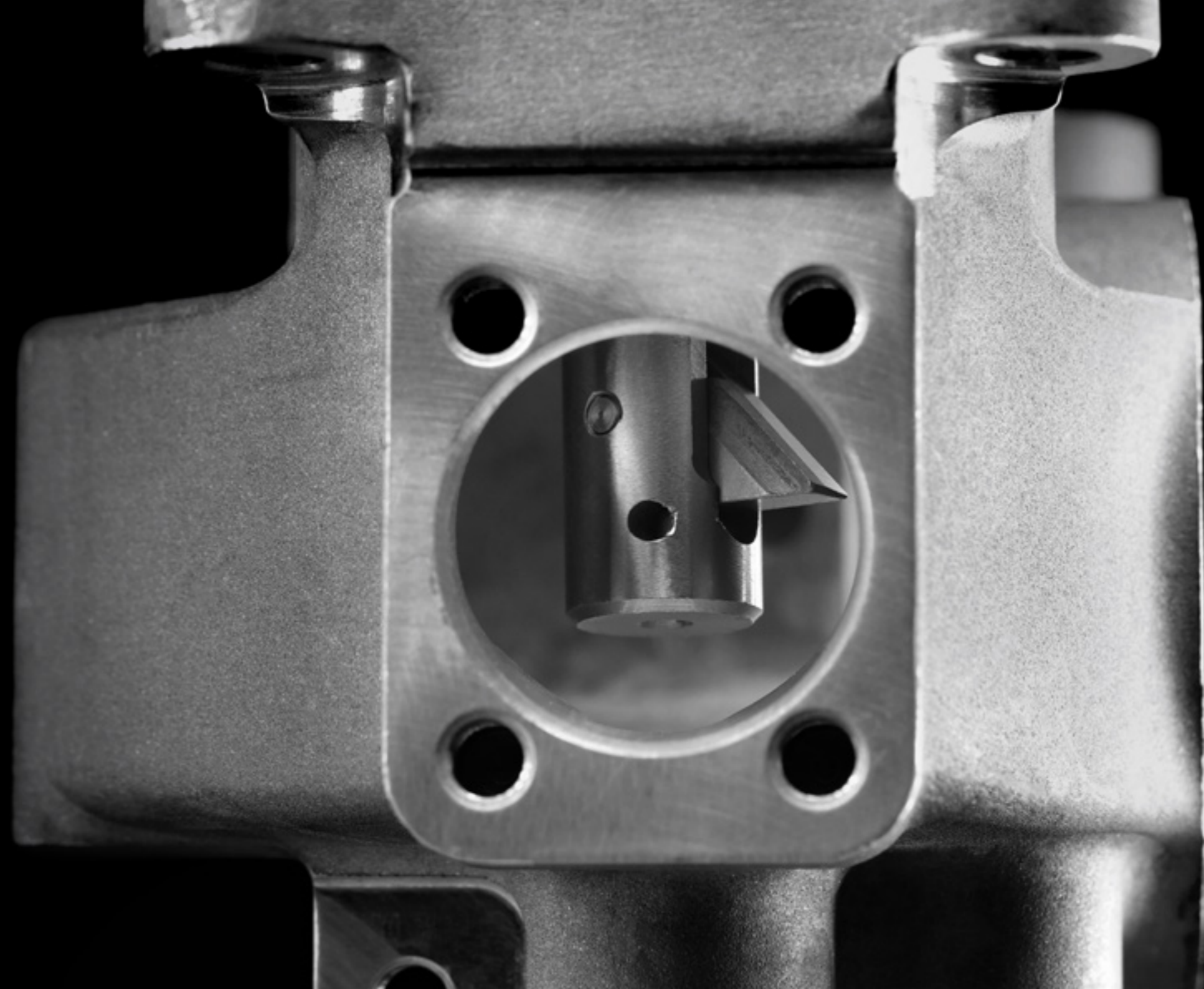

## CUTTING CONDITIONS

### UCHAMF

	HSS		HSS + COATING	TiN	CARBIDE + COATING TiAlN	
	Vc=m/min	Fz=mm/tooth	Vc=m/min	Fz=mm/tooth	Vc=m/min	Fz=mm/tooth
<b>P</b> Steel	25.0-45.0	0.05-0.1	45.0-65.0	0.05-0.1	60.0-110.0	0.05-0.1
<b>M</b> Stainless Steel	15.0-30.0	0.05-0.08	30.0-55.0	0.05-0.08	50.0-90.0	0.05-0.08
<b>K</b> Cast Iron	20.0-35.0	0.05-0.1	35.0-55.0	0.05-0.1	60.0-120.0	0.05-0.1
<b>N</b> Aluminum	40.0-60.0	0.05-0.12	50.0-75.0	0.05-0.12	80.0-130.0	0.05-0.12
<b>S</b> Titanium / Inconel	10.0-15.0	0.05-0.08	15.0-20.0	0.05-0.08	15.0-35.0	0.05-0.08
<b>H</b> Hard Material	15.0-30.0	0.05-0.08	20.0-35.0	0.05-0.08	50.0-70.0	0.05-0.08



# USPOT

## THE MACHINE BACK SPOTFACING TOOL

USpot tools allow back spotfacing with an efficient and consistent way.

USpot tools allow back spotfacing through holes in one operation without turning the workpiece.

The USpot tool is especially designed for automatic operation.

The USpot tool works without an anti-rotation device, change of turning direction or any machine adaptations.

USpot tools are focused on the reliability of the solutions.

This solution is faster, easier, and more economical for your back spotfacing problems for a mass production process.

The opening and closing of the blade are controlled by activating the internal coolant of the machine.

The tool blade designed to protect the hole bore and to unarm the internal surface.

The USpot tool standard series range from Ø8 mm up to Ø20 mm. The tool is available with a different bore diameter.

Custom made tools can be made for your specific applications.





# USPOT NMT-US

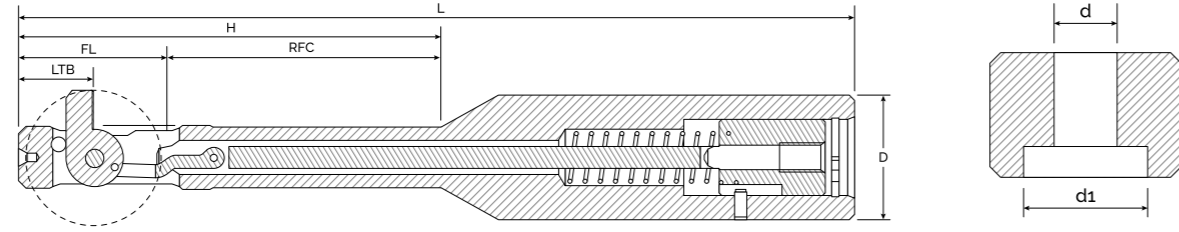

## ONE PASS SOLUTION TO THROUGH-HOLE: BACK SPOTFACING

Tool Item No.	Tool Description	Bore Ød	Bore Ød1 Range	LTB *	RFC **	FL ***	H	D	L	Blade Item No.	Blade item STANDARD	Blade Item No.	Blade item STANDARD
US1080	NMT-US-d080-H40-D16-L114	8.0	11.5-20.0	10.0	40.0	19.0	59.0	16.0	114.0	US2080	NMT-US-B-080 I11.5 HSS	US3080	NMT-US-B-080 I20.0 HSS
US1085	NMT-US-d085-H40-D16-L114	8.5	12.0-21.3	10.0	40.0	19.0	59.0	16.0	114.0	US2085	NMT-US-B-085 I12.0 HSS	US3085	NMT-US-B-085 I21.3 HSS
US1090	NMT-US-d090-H40-D16-L114	9.0	13.5-22.5	10.0	40.0	19.0	59.0	16.0	114.0	US2090	NMT-US-B-090 I13.5 HSS	US3090	NMT-US-B-090 I22.5 HSS
US1095	NMT-US-d095-H40-D16-L114	9.5	14.0-23.8	10.0	40.0	19.0	59.0	16.0	114.0	US2095	NMT-US-B-095 I14.0 HSS	US3095	NMT-US-B-095 I23.8 HSS
US1100	NMT-US-d100-H50-D16-L125	10.0	14.5-25.0	11.0	50.0	22.5	72.5	16.0	125.0	US2100	NMT-US-B-100 I14.5 HSS	US3100	NMT-US-B-100 I25.0 HSS
US1105	NMT-US-d105-H50-D16-L125	10.5	15.5-26.3	11.0	50.0	22.5	72.5	16.0	125.0	US2105	NMT-US-B-105 I15.5 HSS	US3105	NMT-US-B-105 I26.3 HSS
US1110	NMT-US-d110-H50-D16-L125	11.0	16.0-27.5	11.0	50.0	22.5	72.5	16.0	125.0	US2110	NMT-US-B-110 I16.0 HSS	US3110	NMT-US-B-110 I27.5 HSS
US1115	NMT-US-d115-H50-D16-L125	11.5	16.5-28.8	11.0	50.0	22.5	72.5	16.0	125.0	US2115	NMT-US-B-115 I16.5 HSS	US3115	NMT-US-B-115 I28.8 HSS
US1120	NMT-US-d120-H50-D16-L125	12.0	18.0-30.0	12.0	50.0	25.5	75.5	16.0	125.0	US2120	NMT-US-B-120 I18.0 HSS	US3120	NMT-US-B-120 I30.0 HSS
US1125	NMT-US-d125-H50-D16-L125	12.5	18.5-31.3	12.0	50.0	25.5	75.5	16.0	125.0	US2125	NMT-US-B-125 I18.5 HSS	US3125	NMT-US-B-125 I31.3 HSS
US1130	NMT-US-d130-H50-D16-L125	13.0	19.0-32.5	12.0	50.0	25.5	75.5	16.0	125.0	US2130	NMT-US-B-130 I19.0 HSS	US3130	NMT-US-B-130 I32.5 HSS
US1135	NMT-US-d135-H50-D16-L125	13.5	19.5-33.8	12.0	50.0	25.5	75.5	16.0	125.0	US2135	NMT-US-B-135 I19.5 HSS	US3135	NMT-US-B-135 I33.8 HSS
US1140	NMT-US-d140-H50-D16-L125	14.0	20.0-35.0	13.0	50.0	29.0	79.0	16.0	125.0	US2140	NMT-US-B-140 I20.0 HSS	US3140	NMT-US-B-140 I35.0 HSS

All measurements are in mm unless mentioned otherwise | \* Length to bottom | \*\* Relief for cutting | \*\*\* Folding Length

### TOOL DESIGNATION

NMT NOGA  
Machine Tools

US - USPOT

### BLADE/INSERT DESIGNATION

NMT NOGA  
Machine Tools

US - B

### I/Angle

Cutting Length

### Blade Material & Coating

HSS / HSS C(coated)\*  
or CR / CRC\* (CA (Carbide/CAC) Carbide Coated)\*

\* Upon Request

Tool Item No.	Tool Description	Bore Ød	Bore Ød1 Range	LTB *	RFC **	FL ***	H	D	L	Blade Item No.	Blade item STANDARD	Blade Item No.	Blade item STANDARD
US1145	NMT-US-d145-H50-D16-L125	14.5	20.5-36.3	13.0	50.0	29.0	79.0	16.0	125.0	US2145	NMT-US-B-145 I20.5 HSS	US3145	NMT-US-B-145 I36.3 HSS
US1150	NMT-US-d150-H70-D16-L150	15.0	22.0-37.5	13.0	70.0	29.0	99.0	16.0	150.0	US2150	NMT-US-B-150 I22.0 HSS	US3150	NMT-US-B-150 I37.5 HSS
US1155	NMT-US-d155-H70-D16-L150	15.5	22.5-38.8	13.0	70.0	29.0	99.0	16.0	150.0	US2155	NMT-US-B-155 I22.5 HSS	US3155	NMT-US-B-155 I38.8 HSS
US1160	NMT-US-d160-H70-D16-L160	16.0	23.0-40.0	15.0	70.0	34.0	104.0	16.0	160.0	US2160	NMT-US-B-160 I23.0 HSS	US3160	NMT-US-B-160 I40.0 HSS
US1165	NMT-US-d165-H70-D20-L160	16.5	23.5-41.3	15.0	70.0	34.0	104.0	20.0	160.0	US2165	NMT-US-B-165 I23.5 HSS	US3165	NMT-US-B-165 I41.3 HSS
US1170	NMT-US-d170-H70-D20-L160	17.0	24.0-42.5	15.0	70.0	34.0	104.0	20.0	160.0	US2170	NMT-US-B-170 I24.0 HSS	US3170	NMT-US-B-170 I42.5 HSS
US1175	NMT-US-d175-H70-D20-L160	17.5	24.5-43.8	15.0	70.0	34.0	104.0	20.0	160.0	US2175	NMT-US-B-175 I24.5 HSS	US3175	NMT-US-B-175 I43.8 HSS
US1180	NMT-US-d180-H70-D20-L160	18.0	26.5-45.0	17.0	70.0	37.5	107.5	20.0	160.0	US2180	NMT-US-B-180 I26.5 HSS	US3180	NMT-US-B-180 I45.0 HSS
US1185	NMT-US-d185-H70-D20-L160	18.5	27.0-46.3	17.0	70.0	37.5	107.5	20.0	160.0	US2185	NMT-US-B-185 I27.0 HSS	US3185	NMT-US-B-185 I46.3 HSS
US1190	NMT-US-d190-H70-D20-L160	19.0	27.5-47.5	17.0	70.0	37.5	107.5	20.0	160.0	US2190	NMT-US-B-190 I27.5 HSS	US3190	NMT-US-B-190 I47.5 HSS
US1195	NMT-US-d195-H70-D20-L160	19.5	28.0-48.8	17.0	70.0	37.5	107.5	20.0	160.0	US2195	NMT-US-B-195 I28.0 HSS	US3195	NMT-US-B-195 I48.8 HSS
US1200	NMT-US-d200-H70-D20-L168	20.0	28.5-50.0	17.0	70.0	38.0	108.0	20.0	170.0	US2200	NMT-US-B-200 I28.5 HSS	US3200	NMT-US-B-200 I50.0 HSS

All measurements are in mm unless mentioned otherwise | \* Length to bottom | \*\* Relief for cutting | \*\*\* Folding Length



# CUTTING CONDITIONS

## USPOT

	HSS		HSS + COATING	TiN	CARBIDE + COATING TiAlN	
	Vc=m/min	Fz=mm/tooth	Vc=m/min	Fz=mm/tooth	Vc=m/min	Fz=mm/tooth
<b>P</b> Steel	25.0-45.0	0.05-0.1	45.0-65.0	0.05-0.1	60.0-110.0	0.05-0.1
<b>M</b> Stainless Steel	15.0-30.0	0.05-0.08	30.0-55.0	0.05-0.08	50.0-90.0	0.05-0.08
<b>K</b> Cast Iron	20.0-35.0	0.05-0.1	35.0-55.0	0.05-0.1	60.0-120.0	0.05-0.1
<b>N</b> Aluminum	40.0-60.0	0.05-0.12	50.0-75.0	0.05-0.12	80.0-130.0	0.05-0.12
<b>S</b> Titanium / Inconel	10.0-15.0	0.05-0.08	15.0-20.0	0.05-0.08	15.0-35.0	0.05-0.08
<b>H</b> Hard Material	15.0-30.0	0.05-0.08	20.0-35.0	0.05-0.08	50.0-70.0	0.05-0.08

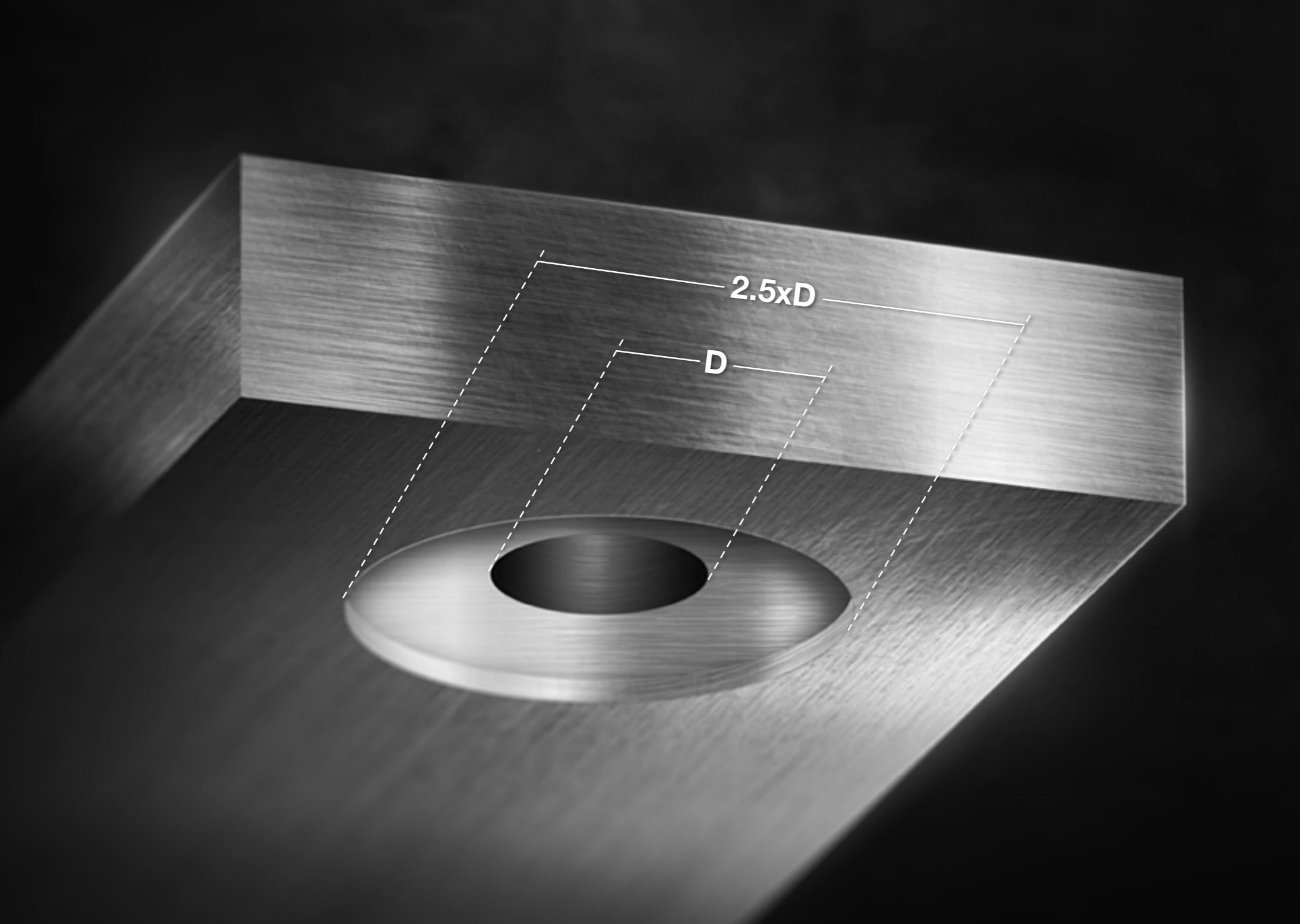

## USPOT & UCHAMF: THE TOOL PATH

ONE PASS SOLUTION TO THROUGH-HOLE:  
BACK SPOTFACING/CHAMFERING

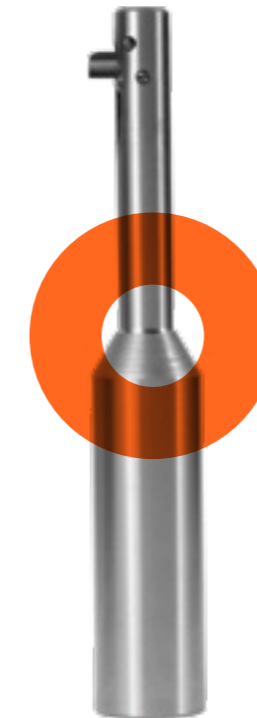

**USPOT**



**UCHAMF**

**USPOT & UCHAMF** are specifically designed for CNC machines with **coolant through** the spindle. The insert expands by spring force and is retracted by coolant pressure of a minimum **6 bar** (90 PSI).

Tool holder with internal cooling

Minimum Coolant pressure 6bar (90PSI)

Coolant must be filtered (filter dimension  $\leq 25 \mu\text{m}$ )

For chip evacuation make sure that there is enough space from the workpiece material

Available Dia 8mm-20mm in the range of every 0.5mm and length of Max 2.5xD USPOT, 2.3xD UCHAMF

USPOT Tool Selection for Counterbores according to DIN 974-1 socket head cap screws

# USPOT & UCHAMF: STEPS

## STEP 1: Position **A**

Internal coolant **ON**  
(wait 2-5 sec to build up the coolant pressure);  
Blade in the pocket.

## STEP 2: Position **A** to **B**

Internal coolant **ON**;  
Blade in the pocket;  
Rapid feed.

## STEP 3: Position **B**

Internal coolant **OFF**  
(Wait 2-3 sec).

## STEP 4: Position **B** to **C**

Internal coolant **OFF**;  
Rapid feed.

## STEP 5: Position **C** to **D**

Internal coolant **OFF**;  
External coolant **ON**;  
Spindle speed **ON**;  
Working feed rate to 0.2-0.3mm  
**into raw material.**

## STEP 6: Position **D**

Internal coolant **ON**;  
External coolant **ON**;  
Spindle speed **ON**.

## STEP 7: Position **D** to **E**

Internal coolant **ON**;  
External coolant **ON**;  
Spindle speed **ON**;  
Working feed rate to the required  
dimensions of the spot/chamfer.

## STEP 8: Position **E**

Internal coolant **OFF**;  
External coolant **OFF**;  
Spindle speed **ON**.

## STEP 9: Position **E** to **C**

Internal coolant **OFF**;  
External coolant **OFF**;  
Spindle speed **ON**;  
Working feed rate.

## STEP 10: Position **C** to **B**

Internal coolant **OFF**;  
External coolant **OFF**;  
Spindle speed **OFF**;  
Rapid feed.

## STEP 11: Position **B**

Internal coolant **ON**;  
External coolant **OFF**;  
Spindle speed **OFF**.

## STEP 12: Position **B** to **A**

Internal coolant **ON**;  
External coolant **OFF**;  
Spindle speed **OFF**;  
Rapid feed.

## STEP 13: Position **B**

Internal coolant **OFF**;  
External coolant **OFF**;  
Spindle speed **OFF**.

## **A** POSITION

Tool is above to  
workpiece hole.

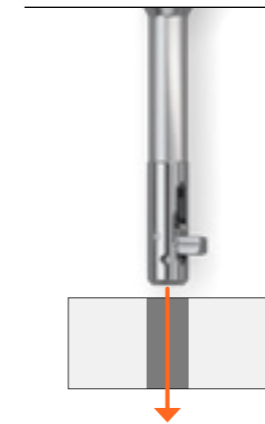

## **B** POSITION

Tool is under the  
workpiece hole  
(FL + workpiece  
thickness + 2 mm).

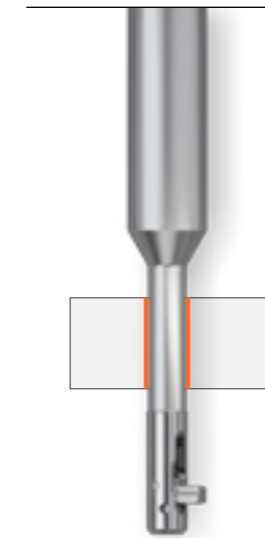

## **C** POSITION

Tool is 1 mm under the  
workpiece hole.

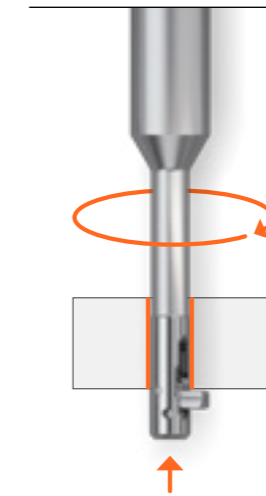

## **D** POSITION

Tool is 0.2mm into the  
workpiece.

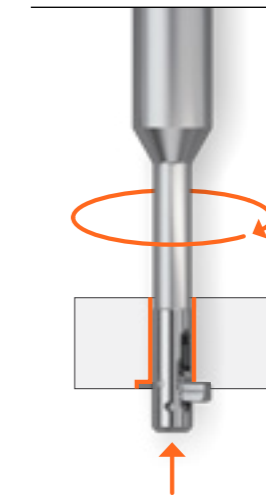

## **E** POSITION

Tool is in the required  
dimensions of the  
spot/chamfer.

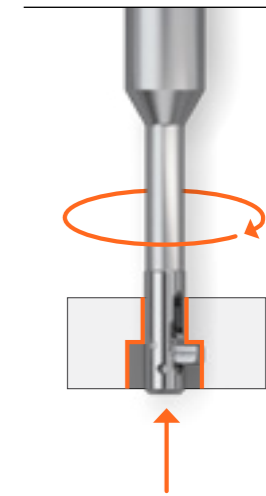

# BLADE REPLACEMENT USPOT & UCHAMF

**1** Locate the tool into the assembly device, push the tool inside the assembly device pin until the blade is covered in the pocket.

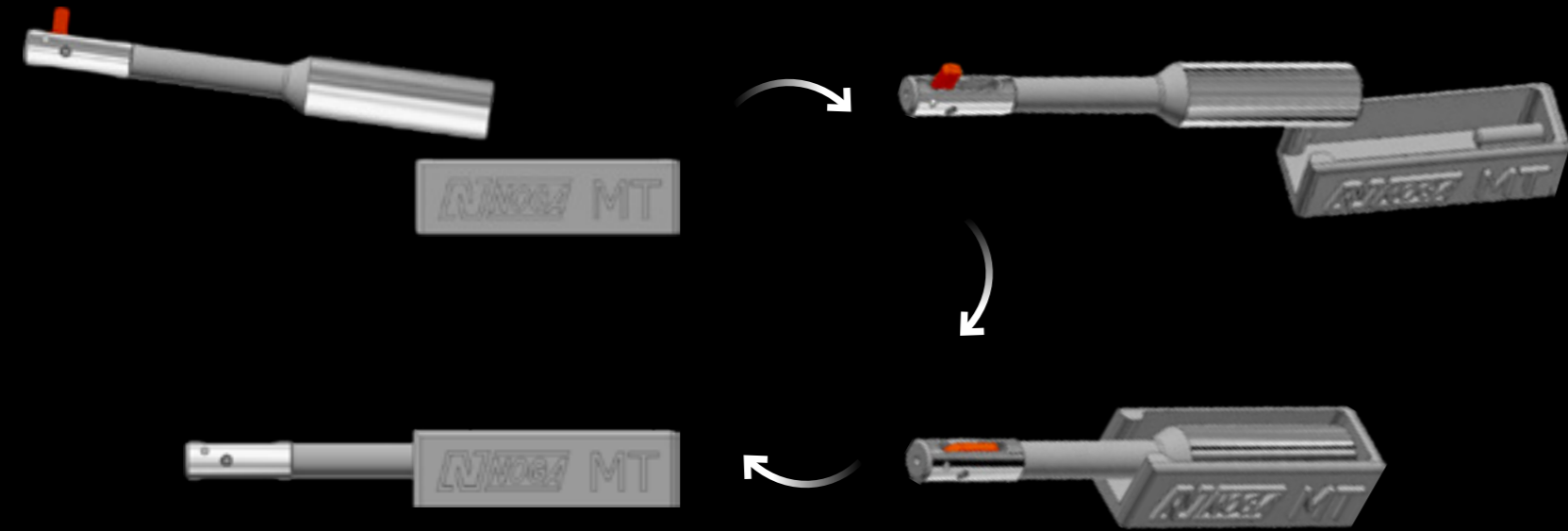

**2** Unlock the locking screw and push the blade out of the tool pocket.

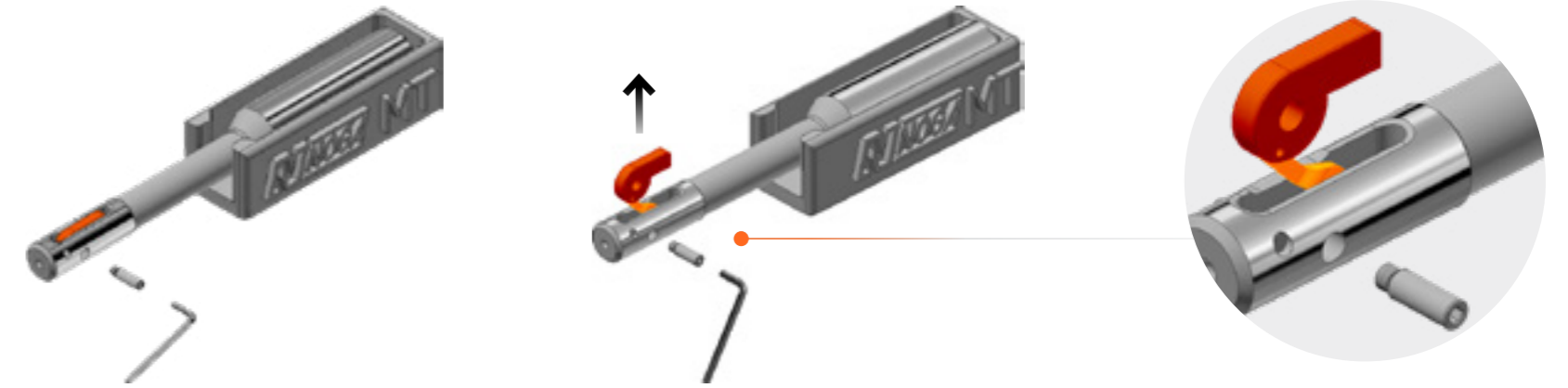

**3** Remove the blade and replace with a new one.

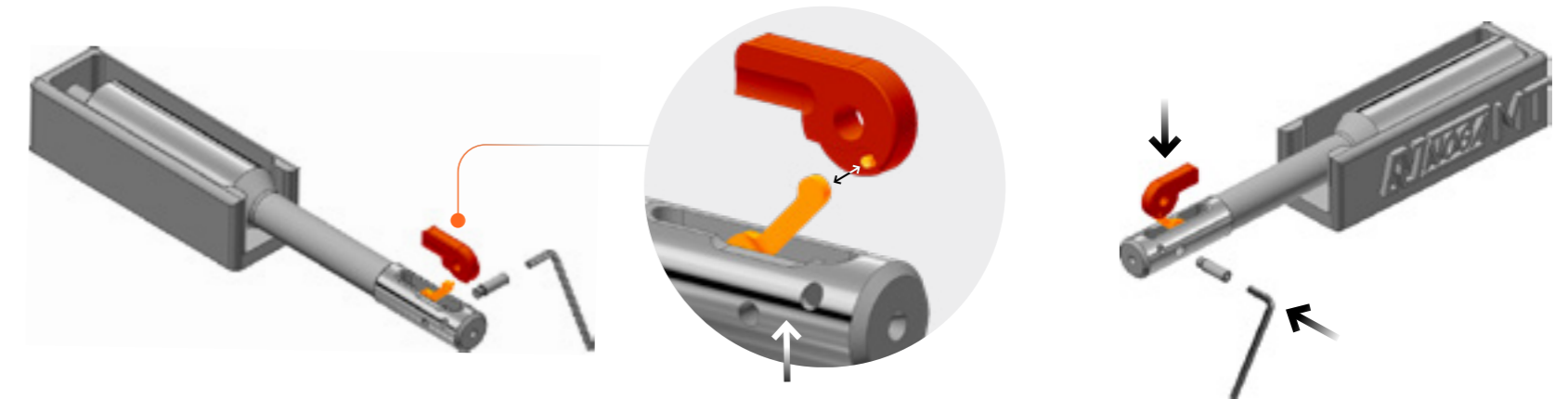

**All NOGA products meet the strict requirements of ISO 9001 and ISO 14001.**

NOGA reserves the right to make changes in any of its products without prior notice. © Copyright NOGA Engineering & Technology (2008) Ltd. All rights reserved. No part of this publication may be reproduced, transcribed, stored in an electronic retrieval system, translated into any language or computer language, or be transmitted in any form whatsoever without the prior written consent of the publisher.

---

**NOGAMT**



Contact your local representative  
[sales@pts-tools.com](mailto:sales@pts-tools.com)

Dotan-Lidgi

**NOGANT**

THE ULTIMATE SERIES